



USER MANUAL

**FRYING MACHINE/CHURRO FRYER**

**PNH**

**//ELECTRIC**

## SYMBOLS USED IN THIS MANUAL



Read the instructions before using the appliance.



Important safety instructions. Imminent danger of accident if not observed.



**Practical note for the user.**



Instructions for qualified persons only.



This symbol means that the product must be collected separately at the end of its life cycle. Do not dispose of it in municipal waste bins as if it were ordinary household waste. **DIRECTIVE 2002/96/EC;**



The product concerned is manufactured in compliance with the Low Voltage Equipment Directive 5/EC.

### 1. SAFETY AND PROPER USE

#### 1.1. Safety instructions

The equipment is safe to use and meets the current European safety requirements. However, improper use can lead to personal injury and property damage. To ensure correct and safe operation, read this manual before using the equipment. This manual contains important warnings about installation, safety, use and care of the equipment.

Keep this manual for future reference. Give the manual together with the equipment to a possible new owner of the equipment.

The manufacturer cannot be held responsible for damages that result from inappropriate or incorrect use. Please note that the instructions in this manual do not replace the technical characteristics engraved on the rating plate fixed to the equipment.











**Read the safety instructions carefully!**





During installation: do not place on surfaces or close to walls, partitions, kitchen furniture or similar unless they are made of non-combustible material or covered with thermally insulating and non-combustible material, and attention is paid to fire prevention regulations.



**Before using the equipment, check that no damage is visible.  
Never use a damaged device.**

-  **To avoid risk of damage to the equipment, check that the data indicated on the rating plate of the equipment corresponds to the voltage and frequency of the power supply.**
-  **Connect the equipment to an earthed electrical circuit.**  
**The electrical safety of the equipment is only guaranteed if it has a correct connection.**
-  **This equipment is supplied with an equipotential bonding terminal on the underside of the heating element, which must be properly connected to the earth circuit by an authorised installer.**
-  **Do not connect the equipment to the power supply using a multiple plug or an extension cable. These do not guarantee the safety of the equipment.**
-  **Only qualified and authorised persons may carry out installation and repairs to the equipment. The manufacturer is not responsible for damage resulting from repairs or other interventions carried out by unqualified persons.**
-  **Installation and repair interventions must strictly comply with the local and national safety regulations in force.**
-  **Keep your equipment clean at all times by carrying out a thorough cleaning on a regular basis! Food residues accelerate oil degradation!**
-  **Fire hazard! Do not operate the equipment with the oil level below the minimum mark.**
-  **Danger of burns! Do not touch work surfaces and metal parts while the equipment is running.**

-  **Danger of burns! Do not open the oil drain valve while the oil is hot.**
-  **Danger of burns! Do not use deteriorated oil, failure to comply with this recommendation will cause the boiling point to fall and boiling may occur abruptly.**

### 1.2. Purpose of use

Farturas machines are designed for frying food products. The manufacturer does not recommend any other type of use; failure to comply could compromise the safety of the equipment and of the user. Frying machines are intended for commercial use. Do not use the equipment outdoors.

### 1.3. User requirements

The equipment should be kept out of the reach of children and they should be supervised to ensure that they do not play with the equipment.

### 1.4. Recycling

Treatment of packaging material: Before using the device for the first time, remove the protective plastics from the stainless steel. Recycle the transport packaging and all protective materials.

-  Ensure safe disposal of all plastic packaging. Keep plastic packaging out of the reach of children. Danger of suffocation!



Electrical and electronic equipment contains materials that when incorrectly handled can endanger human health and the environment. Do not dispose of any part or component of the equipment in domestic waste, take them to collection/recycling facilities or contact your supplier or local authority for advice.

## 2. DESCRIPTION

### 2.1. Technical Features

| Model                                   |                       | Frying Machine 700 E | Frying Machine 800 E |
|---|-----------------------|----------------------|----------------------|
| Equipment dimensions                    | Width (mm)            | 700                  | 800                  |
|   | Depth with head (mm)  | 860                  | 960                  |
|   | Height with head (mm) | 1000                 | 1000                 |
| Minimum oil capacity / Maximum capacity | Litres                | 22L / 29L            | 29.7L / 39L          |
|   | Power                 |                      |                      |
|   | KW                    | 13.5                 | 20.5                 |
|   | Tension (V/Hz)        | 380/50               | 380/50               |
| Net weight (kg)                         |                       | 35                   | 41                   |
| Gross Weight (kg)                       |                       | 42.5                 | 48.5                 |
| Packing Dimension WxDxH (mm)            |                       | 790X790X850          | 890X890X850          |
| Product dimensions WxDxH (mm)           |                       | 700X700x1000         | 800X800X1000         |

### 2.2. Required links

Electrical connection with protective earthing.

Equipotential bonding.

### 2.3. Location of use

Choose a dry place where the equipment cannot come into direct contact with water.



Never direct jets of water at the equipment.

Place the equipment on a stable, level surface.



Keep the equipment away from flammable or heat-deformable materials. If this is not possible, insulate the space around the equipment with a non-flammable, heat-resistant insulating material.



Install in a place where there is no risk of water falling on the oil.

#### 2.4. Unpack

Remove all protective material from the packaging. Check the equipment.

Remove the protective plastics from the stainless steel. Clean the outside of the unit with a damp cloth.

Dispose of the protective material and packaging safely, as they are potential sources of danger.

#### 2.5. Electrical installation

Check that the data indicated on the rating plate of the unit corresponds to the voltage and frequency of the power supply.

Connect the unit to an earthed electrical circuit!

Connect the equipment to a fixed installation. Never connect the equipment to multiple sockets, T-type adapters or extension leads.

Models sold without a plug must be equipped with a means of disconnection from the electrical installation in accordance with installation regulations.

Follow the regulations in force in the country you are in.



On the back of the appliance there is a terminal marked with the symbol  for equipotential bonding between different appliances.

### 3. OPERATING INSTRUCTIONS

- Before using the appliance you must remove all the protective plastic from around the appliance and clean the glue particles with non-abrasive products so as not to damage the appliance.
- When choosing where to place the appliance, you should ensure that it is level and that its surface is made of non-combustible material. The appliance should also be kept away from walls and other materials that could break up or catch fire when heated.
- Before connecting the appliance to the mains supply, make sure that the voltage shown on the rating plate corresponds to the mains voltage and check that the socket is capable of supporting the current of the appliance.
- After the previous checks, you can use the appliance by connecting the power cable to the mains and turning the temperature knob to the desired value.
- Never operate the fryer with wet hands!
- To adjust the temperature, turn the thermostat knob to the required value.
- When using the appliance, do not place cloth or other objects on it that could be damaged or cause any hazard.
- Please note that the power cable must not come into contact with heating elements or other hot parts.

### 4. CLEANING

- When cleaning the appliance, make sure the power cable is disconnected from the mains and that the appliance is completely cool.
- Remove the oil by placing a drip tray under the tap. To open the tap, press the handle and turn it a quarter of a turn anticlockwise. **Never do this when the oil is still hot.**
- Separate the heating module from the bowls.
- The fryer bowls can be cleaned with plenty of water and detergent.
- The heating module can be immersed in the heating elements up to the **maximum limit marking**.

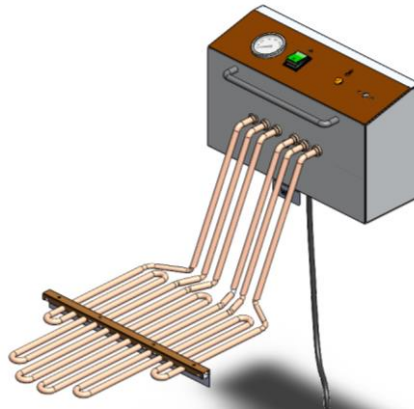



Note: the level of immersion must not be exceeded, otherwise damage may be caused to the equipment and the user may be endangered.

 Note: the level of immersion must not be exceeded, otherwise damage may be caused to the equipment and the user may be endangered.

## 5. MAINTENANCE

 Only properly qualified and accredited persons may carry out installation and repairs to the equipment.

 The manufacturer is not liable for damage resulting from repairs or other work carried out by unqualified persons.

 Installation and repair interventions must strictly comply with the local and national safety regulations in force.

 Only original accessories should be used for repair work.

### 5.1. Safety thermostat reset:

here is a hole in the bottom of the heating element where the safety thermostat reset button is located (red/orange colour).

After checking that the normal conditions for the operation of the appliance have been met, press the said button, if the problem persists contact an authorised repairer.

### 5.2. Replacing the power cable:

 If the power cable is damaged, it must be replaced only by an authorised repairer or by the manufacturer.

- Single and Dual models, cable type H07RN-F 5G2,5 mm<sup>2</sup>.

### 5.3. Most frequent anomalies:

| Anomaly   | Possible cause/solution                       |  |  |   |
|---|---|--|--|---|
| Fryer does not switch on (green light does not come on)               | Power supply fault (check switchboard)        | Heating element not properly fitted (check fitting position) | Safety thermostat activated (reset thermostat) | Internal fault (contact technical assistance) |
| Fryer switches on, but shortly afterwards safety thermostat activates | Low oil level (correct)                       | Internal fault (contact technical assistance)                |  |   |
| Fryer turns on but does not heat up properly                          | Power supply fault (check presence of phases) | Internal fault (contact technical assistance)                |  |   |

## //GAS

### SYMBOLS USED IN THIS MANUAL



Read the instructions before using the appliance;



Important safety instructions. Imminent danger of accident if not observed.



**Practical note for the user.**



Instructions only for suitably qualified persons.

### INTRODUCTION:

Congratulations on the excellent choice you have just made...!

Before starting to use the equipment you have just purchased, please read the instruction manual carefully and completely.

The installation, repair and adaptation to other types of gas must be carried out exclusively by accredited technicians.



Never use the appliance for purposes for which it is not intended.

This equipment has been developed for professional use and should not be used by untrained persons.

**Never allow to be used by children.**

For hygiene and safety purposes keep the equipment clean at all times.



Keep the instruction manual for the duration of the equipment's life for the clarification of any possible doubts.



### CONSTRUCTION:

- Stainless steel 304 construction;
- Brushed steel finish;
- Rubber wheels (front brakes);
- Chimney extension.



## CHARACTERISTICS:

- Burner with double safety gas valve;
- Digital microprocessor temperature control;
- Rear gas inlet (1/2" thread);
- Factory prepared for G31;
- Supplied with restriction for conversion to G20 and corresponding conversion label.

## TABLE OF CONTENTS:

| Frying Machine 800 G    |                                |              |
|-------------------------|--------------------------------|--------------|
| Dimensions of Equipment | Width (mm)                     | 800          |
|                         | Depth (mm)                     | 830          |
|                         | Overall depth with handle (mm) | 915          |
|                         | Height without chimney (mm)    | 846          |
|                         | Height with chimney (mm)       | 1250         |
|                         | With packaging (WxDxH)         | 850x880x1000 |
| Maximum oil capacity    | Litres                         | 26           |
| Frying capacity         | Kg/h                           | 25           |
| Power                   | kW                             | 18.5         |
|                         | Kcal                           | 15,91        |
| Consumption Nominal     | G31, 37mbar (kg/h)             | 1,437        |
|                         | Natural Gas, 20mbar (m³/h)     | 1,956        |
|                         | 230V/50Hz (kW/h)               | 0,1          |
| Flow restrictors        | G31, 37mbar                    | 5,5          |
|                         | Gás Natural, 20mbar            | 8            |
| Net weight (kg)         |                                | 73           |
| Gross Weight (kg)       |                                | 78           |

## 1. SAFETY AND PROPER USE

### 1.1. Safety instructions















The equipment is safe to use and meets the current European safety requirements. However, improper use can lead to personal injury and property damage.

To ensure correct and safe operation, read this manual before using the equipment. This manual contains important notices about installation, safety, use and care of the equipment.

Keep this manual for future reference. Give the manual together with the equipment to a possible new owner of the equipment.

The manufacturer cannot be held responsible for damages that result from inappropriate or incorrect use. Please note that the instructions in this manual do not replace the technical characteristics engraved on the rating plate fixed to the equipment..



-  **Read the safety instructions carefully!**
-  **Only qualified and authorised persons may carry out installation, adaptation to another type of gas or repairs to the equipment. The manufacturer is not liable for damage resulting from repairs and other interventions carried out by unqualified persons.**
-  During installation: do not place on surfaces or close to walls, partitions, kitchen furniture or similar unless they are made of non-combustible material or covered with terminally insulating and non-combustible material, and attention is paid to fire prevention regulations.
-  **Before using the equipment, check that no damage is visible. Never use a damaged device.**
-  **The equipment must be installed on a flat floor with a non-slip surface.**
-  **The installation must be done under an exhaust system sized according to the standards in force in the country. Ensure that the ventilation is sufficient so that there is no concentration of dangerous gases from combustion.**
-  **To avoid the risk of damage to the equipment, check that the power supply meets the requirements indicated on the equipment's rating plate.**  
**Respect the phase position of the power supply!**
-  **Connect the equipment to an earthed electrical circuit.**  
**The electrical safety of the equipment is only guaranteed if it is correctly connected.**
-  **Do not connect the equipment to the power supply using a multiple socket or an extension lead. These do not guarantee the safety of the device.**
-  **Installation and repair interventions must strictly comply with the local and national safety regulations in force.**
-  **The appliance is equipped with a burner whose flow rate is factory preset for the type of gas shown on the specifications label. This setting must not be altered, as this could cause serious damage to the appliance or even the user.**
-  **In the event of a malfunction refrain from attempting any type of intervention. Disconnect the equipment from the electricity and gas supply and contact an authorised repairer.**
-  Keep the equipment always clean, you should carry out a thorough cleaning regularly! Food residues increase the risk of fire.
-  **Do not operate the equipment with the oil level below the minimum mark. Failure to comply leads to overheating of the oil, fire hazard!**
-  **Danger of burns! Do not touch work surfaces and metal parts while the equipment is running.**

 **Danger of burns! Do not open the oil drain valve while the oil is hot.**

 **Danger of burns! Do not use deteriorated oil. Failure to comply with this recommendation will cause the boiling point to fall and boiling may occur abruptly.**

#### 1.2. Purpose of use

PNH frying machines are designed for frying food products, in particularly farturas and churros. The manufacturer does not recommend any other type of use, failure to comply could compromise the safety of the equipment and the user.

Fryers are intended for commercial use. Do not use the equipment outdoors.

#### 1.3. User requirements

The equipment must be kept out of the reach of children and they must be supervised to ensure that they do not play with the appliance.

The user must have access to the information contained in this manual and comply with all the recommendations given herein.

#### 1.4. Recycling

Treatment of packaging material: Before using the device for the first time, remove the protective plastics from the stainless steel. Recycle the transport packaging and all protective materials.



Ensure safe disposal of all plastic packaging. Keep plastic packaging out of the reach of children. Danger of suffocation!



Electrical and electronic equipment contains materials that when incorrectly handled can endanger human health and the environment. Do not dispose of any part or component of the equipment in domestic waste, take them to collection/recycling facilities or contact your supplier or local authority for advice.

## 2. INSTALLATION

### 2.1. Unpack

Remove all protective material from the packaging. Check the equipment.

Remove the protective plastics from the stainless steel. Clean the outside of the unit with a damp cloth. Dispose of the protective material and packaging safely, as they are potential sources of danger.

### 2.2. Required links:

#### 2.2.1. Electrical installation

Check that the data on the device's rating plate correspond with the voltage and frequency of the power supply.

Connect the device to an earthed electrical circuit!

Ensure the correct connection of the active conductor (brown conductor - phase).

Connect the device to a fixed installation. Never connect the equipment to multiple sockets, T-type adapters or extension leads.

Follow the regulations in force in the country you are in.



On the back of the appliance there is a terminal marked with the symbol  for equipotential bonding between different appliances.

#### 2.2.2. Gas installation

Check that the equipment is prepared for the type of gas to be used.

If it is not, contact an authorised installer for the conversion operation.

Make the gas inlet pipe connection in accordance with the standards in force. Avoid tensile or torsional stress.

We recommend connecting the appliance using a rigid (copper) or flexible metal-coated connection. This should be periodically checked and replaced if necessary.

The equipment must be connected to an installation fitted with an individual shut-off valve.

### 2.3. Location of use



Choose a dry place where the equipment cannot come into direct contact with water.



Never direct jets of water at the equipment.



Place the equipment on a stable, level surface. **Lock wheels before starting use.**



Keep the equipment away from flammable or heat-deformable materials. If this is not possible, insulate the space around the equipment with a non-flammable, heat-resistant insulating material.



Do not subject the equipment to heat sources. Ensure correct ventilation of the machine's surroundings.



### 3. OPERATING INSTRUCTIONS:

- Before using the appliance you must remove all the protective plastic from around the appliance and clean the glue particles with non-abrasive products so as not to damage the appliance.
- When choosing where to place the appliance, you should ensure that it is level and that its surface is made of non-combustible material. The appliance should also be kept away from walls and other materials that could come apart or catch fire when heated.
- Check that the oil level is within limits and fit for use.
-  Do not add oil to the existing if it is hot, danger of burns!
- Before switching the appliance on, check that the power supply conditions are guaranteed.
- After the above checks you can use the appliance.
- Do not operate with wet hands!
- To make the temperature setting press the "Set" key of the temperature controller for 3 seconds, the preset temperature will appear on the display and the active contact

indication led will start flashing on the display, adjust using the ▼ and ▲ keys, confirm the desired value by pressing the "Set" key again. The change will be saved!

- Avoid placing wet food, drain well and place it in the oil gradually to prevent it from boiling over. **Danger of burns!**



Do not place any objects on or near the chimney during use!

#### 4. CLEANING

- When cleaning the appliance, make sure it is unplugged from the mains and completely cool.
- Drain the oil by placing a drip tray under the tap. To open the tap, turn the handle a quarter turn.



Never carry out this operation when the oil is still hot, as there is a risk of burns!

- When cleaning the appliance, do not use water jets, as you risk damaging the electrical part.



Do not use flammable cleaning products, fire hazard

#### 5. ADAPTATION TO OTHER TYPES OF GAS.

The unit is prepared to work with other types of gas besides the factory setting. A restrictor required for conversion is supplied with the manual.

Any modification to another type of gas must only be carried out by an authorised installer/repairer. Contact the manufacturer to find out the nearest agent.

#### 6. MAINTENANCE

Only qualified and authorised persons may service the equipment. The manufacturer is not responsible for damage resulting from repairs or other interventions carried out by unqualified persons.

Installation and repair interventions must strictly comply with the local and national safety regulations in force.

The equipment should be subjected to an operation / leakage check once a year. If the appliance is installed in mobile establishments, this check should be carried out after each journey.

When it is necessary to replace any of them, ask to use only original parts.

It is recommended that an analysis of the gases resulting from combustion should be carried out at least once per component and only once a year in accordance with the standards in force. Carry out any necessary adjustments.

##### 6.1. Description main components

1. Chimney;
2. Frying pan with combustion chamber;
3. Firing display;
4. Combustion Chamber Cover;
5. Burner;
6. Gas valve assembly;
7. Body;
8. Burner malfunction signalling;
9. Digital thermostat/microprocessor;
10. Main switch;
11. Safety thermostat;
12. Power cable;

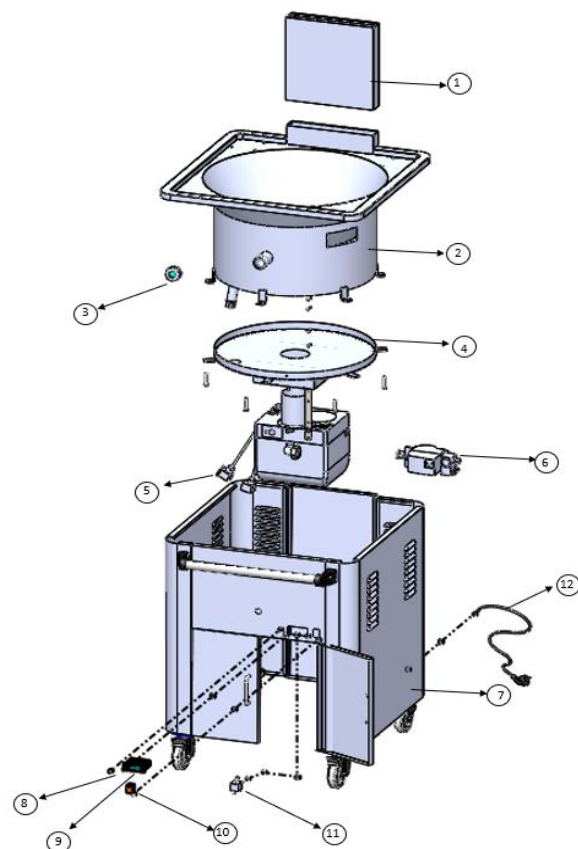

## 6.2. Anomalies and possible causes

| Anomalies  | Possible causes                                 |   |   |  |
|--|---|---|---|--|
| Burner does not start.   | No or insufficient gas pressure (check supply). | Power supply failure (check).   | Safety thermostat active (check condition and reset or replace) | Control thermostat deprogrammed or damaged (check condition, program or replace) |
| Burner starts but flame does not remain active (burner fault signal active). | Insufficient gas pressure (check supply).       | Power supply not by requirements (check earth connection and phase position). | Contact authorised technical assistance.                        |  |

If any anomaly is detected at the burner level (red light on the front panel active) and it is possible to eliminate its origin, it must be reset.

There is a hole in the bottom of the burner that allows access to the reset/diagnostic button, if you press it for more than one second, and no more than two, the burner will restart after approximately 30 seconds.

## 5.3. Passive wear components:

| Reference  | Description   |
|------------|---|
| 1MS0023019 | Microprocessador XT110C-5C0TU                               |
| 1MS0023029 | Microprocessor probe XT110C-5C0TU                           |
| 1MS0023027 | Safety thermostat 220°C                                     |
|            | Termostato segurança falta óleo 250°C                       |
| 1MS0029004 | Bipolar Switch 16A Signal Light 220V orange with protection |
| 1MS0021001 | 230V Red Beacon   |
| 1MS0004011 | H05RN-F 3G 1,5mm cable                                      |
|            | Grey replacement wheel                                      |

Note:

All the components considered as belonging to the gas system are on a list available only to authorised technicians. If intervention on this point is required, contact an authorised repairer.

## 6. WARRANTY

- ❑ The equipment is guaranteed for a period of 12 months from the date of purchase.
- ❑ The guarantee is valid against original defects, whether material or manufacturing.
- ❑ Whenever an anomaly is found in the equipment, it should be returned as soon as possible, enclosing the purchase document.
- ❑ When the guarantee is activated, the damaged parts will be repaired or replaced at the manufacturer's discretion. In the event of replacement, the damaged parts shall become the property of the supplier.
- ❑ Any and all faults resulting from poor installation or use/handling of the equipment are excluded from the scope of the warranty.
- ❑ The equipment will lose its guarantee whenever any alteration/modification or even repair carried out by the user is identified.

PNH BY PINHA

RUA DO ALTO  
VALE DO GROU – APARTADO 86  
3750 - 064 AGUADA DE CIMA

TEL. +351 234 690 190  
geral@pnh-bypinha.pt